



NEW YORK AIR BRAKE

748 Starbuck Ave, Watertown, NY 13601
Phone: +1-315-786-5200 Engineering Fax: +1-315-786-5673

TEST SPECIFICATION NYT-909-C

CODE OF TESTS FOR TESTING "AB" TEST RACK
P/N 702546 & 702612

ISSUE NO. 5
FEBRUARY 12, 2009

SPEC. NYT-909-C
16 PAGES

1.0 THE "AB" TEST RACK (FIGURE 1)

1.1 General Description and Accessories

1.1.1 To obtain the best results in air brake operations, it is essential that the unit devices comprising the complete equipment be maintained in the state of highest practical efficiency.

1.1.2 The test is employed for the purpose of determining promptly and accurately, whether the valves are up to proper standard of workmanship and general condition and if not, where they deviate from the standard.

The following accessories are illustrated by Figure 2.

1. Blanking Plate for testing the test rack	P/N 746417	(TA-2300-C)	Pc. 525620
2. Pipe Bracket Gasket	P/N 746123	(TA-1301)	Pc. 096715
3. Eastman Timer, or any other approved timing devices for timing tests.	P/N 703567	(N-8876)	Pc. 69556
4. A flange, for use when making hydrostatic tests on the two compartment reservoir, where required by law.	P/N 749480	(PF-954)	
5. ABD-1 Test Plate	P/N 746955	(TA2972-C)	Pc. 569058
6. Service Portion Gasket,	P/N 746125	(TA-1302-A)	Pc.525669
7. AB-2 Test Plate	P/N 746254	(TA-1479-C)	Pc. 500895
8. Emergency Portion Gasket,	P/N 746122	(TA-1300)	Pc. 96717
9. AB-160 Test Plate	P/N 747039	(TA-2942-C)	Pc. 564225

Diagrammatic view and arrangement of test item and test rack is shown on Drawing NYT-909.

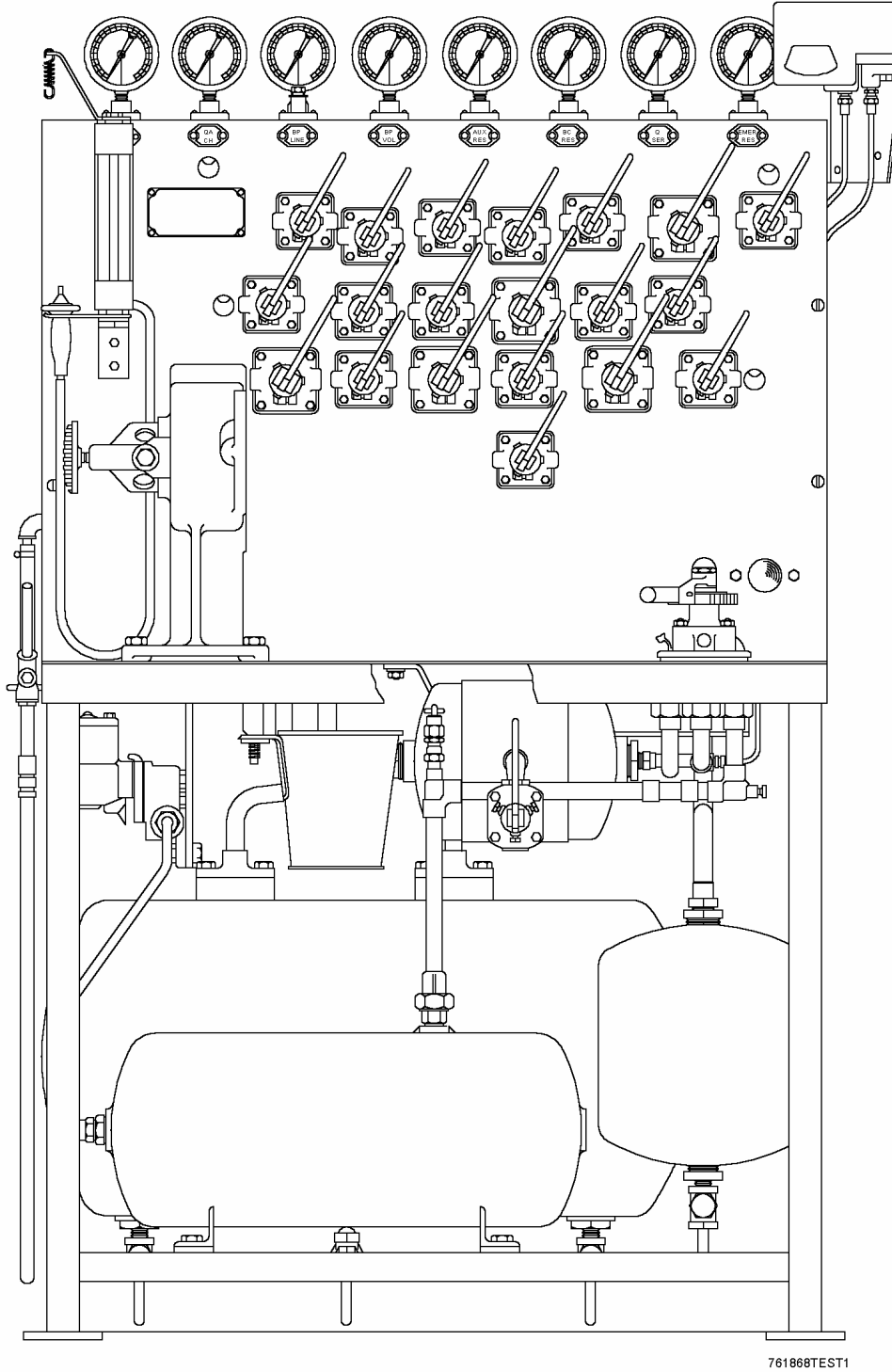

761868TEST1

**FIGURE 1 "AB" Test Rack Equipped with Mechanical Manometer
And Spool type "B"**

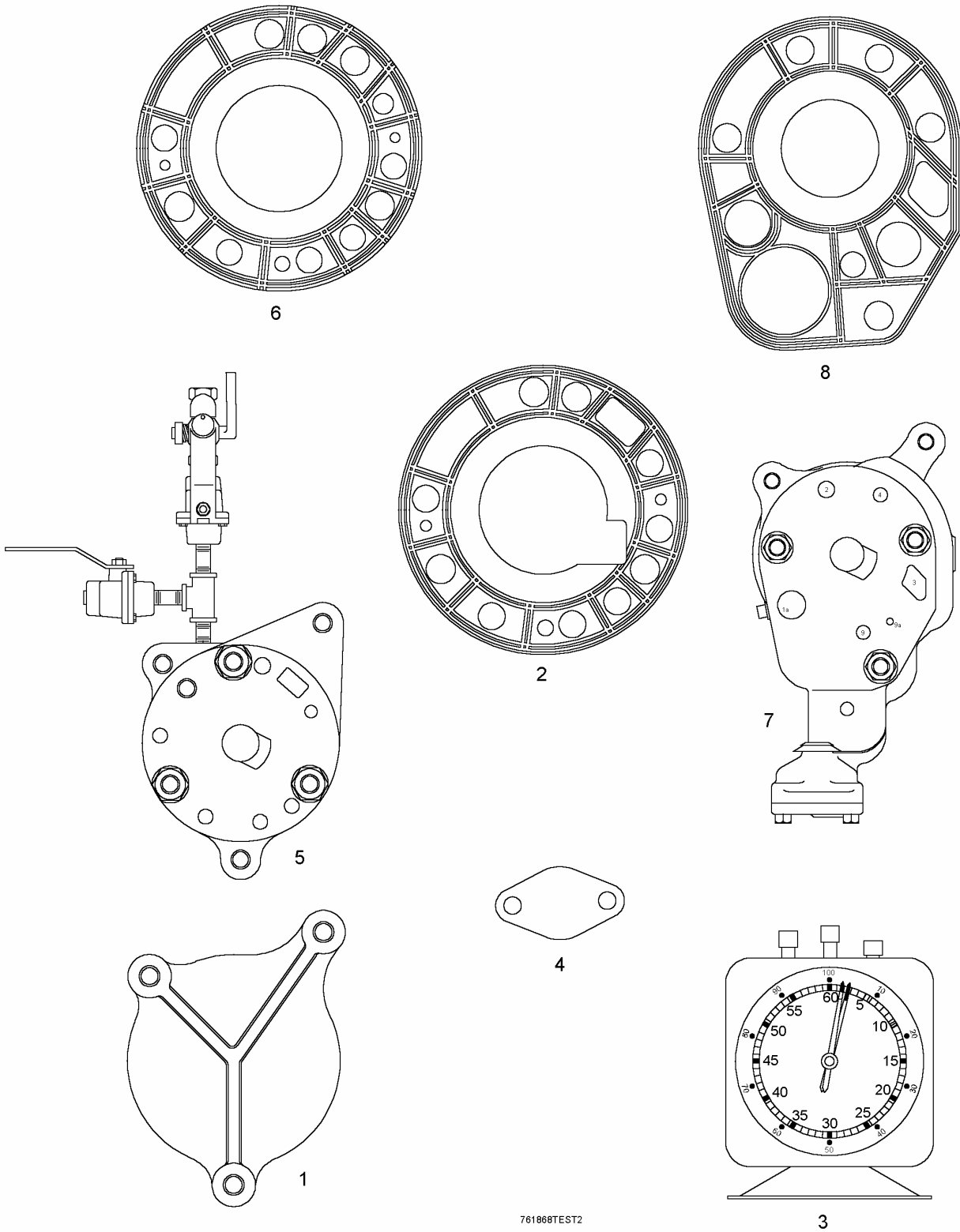

761868TEST2

FIGURE 2
Accessories used with "AB" Test Rack

1.2 Description of Cocks

- Cock 1 -3/4" Brake Pipe Cut-Out Cock
- Cock 2 -3/4" Auxiliary Reservoir Cut-Out Cock
- Cock 3 -3/4" Brake Cylinder Cut-Out Cock
- Cock 4 -3/8" Brake Cylinder Vent Cock
- Cock 5 -3/4" Emergency Reservoir Cut-Out Cock
- Cock 6 -3/8" Emergency Reservoir Vent Cock
- Cock 7 -3/8" Auxiliary Reservoir Vent Cock with No. 63 Drill (.037")
- Cock 8 -3/8" Exhaust Cock
- Cock 9 -3/8" By-pass Cock, Main Reservoir to Emergency Reservoir
- Cock 11 -3/8" Brake Cylinder Reservoir Cut-Out Cock
- Cock 12 -3/8" Brake Cylinder Vent Cock
- Cock 13 -3/8" By-pass Cock, Main Reservoir to Brake Cylinder
- Cock 14 -1/2" By-pass Cock with No. 50 Drill (.070") Choke, Main Reservoir to Auxiliary Reservoir
- Cock 15 -3/8" Quick Action Chamber Vent Cock
- Cock 16 -3/8" By-pass Cock, Brake Pipe Reservoir to Auxiliary Reservoir
- Cock 17 -3/8" By-pass Cock with 3/16" (.1875") Choke, Auxiliary Reservoir to Brake Cylinder
- Cock 18 -3/8" Auxiliary Reservoir Vent Cock with No. 73 Drill (.0240") Choke
- Cock 19 -3/8" By-pass Cock, Auxiliary Reservoir to Quick Action Chamber
- Cock 20 -3/8" Quick Action Chamber Cut-Out Cock
- Cock 22 -3/8" Brake Pipe Vent Cock, P/N 702159 (N-6911) Pc. 538969, 3/8" Choke Plug (No. 30 Drill), P/N 746726 (TA-2679) Pc. 546146, located in downstream opening of Cock 22

1.2.1 The following cocks are relative to the Ring Leakage FLOWRATOR Meter when test rack is so equipped.

- Cock 7 -3/8" Auxiliary and Quick Action Chamber Line Vent Cock with special choke (see Note).
- Cock 24 -3/8" By-pass Cock with special choke (see Note), Main Reservoir to Auxiliary and Quick Action Chamber Lines.
- Cock 25 -1/4" Ring Leakage FLOWRATOR Meter Cut-Out Cock

1.3 QUICK OPENING DIAPHRAGM COCK (FIGURE 3)

1.3.1 The distinctive features of this diaphragm cock are: (a) the quick opening lever type handle, the radial position of which is adjustable to any angle, and (b) controlled diaphragm deflection, by means of an adjustment which regulates the amount of travel of the parts transmitting handle movement to the diaphragm.

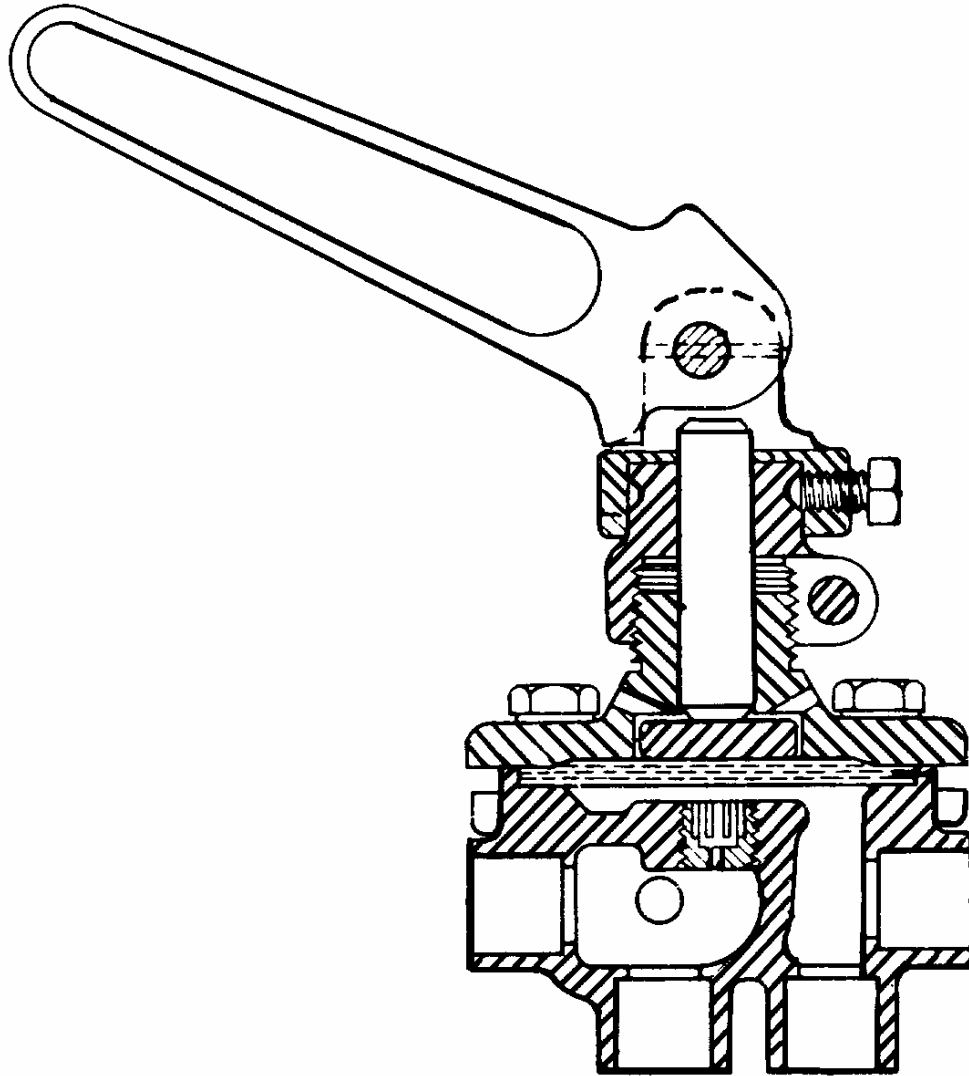

761868TEST3

FIGURE 3
Sectional View of the Quick Opening Diaphragm Cock
with Lever Type Handle

1.4 FLOWRATOR METER (FIGURE 4)

1.4.1 The FLOWRATOR Meter, as illustrated in Fig. 4, is an instrument to provide a means of observing and determining quickly and accurately the permissible leakage on air brake devices. It consists of a float or indicator enclosed with a precision ground tapered glass tube and the flow of air to be measured is admitted to the bottom of the tube. The rate of flow is then measured direct by the height to which the air causes the float to rise in the tube. A graduated scale, located on the right side of the tube, indicates this rate of flow in cubic-inches of free air per minute. By observing the figure at which the float balances in a stationary position, the rate of flow can be determined instantly. The instrument is used in the same manner as the 'Leakage Indicator' and has the standard hose fittings, hose and hose nozzle attached to it. Also, it is attached to the test rack in the same manner as the 'Leakage Indicator', except for a few minor changes in fastening the FLOWRATOR Meter to the present mounting bracket.

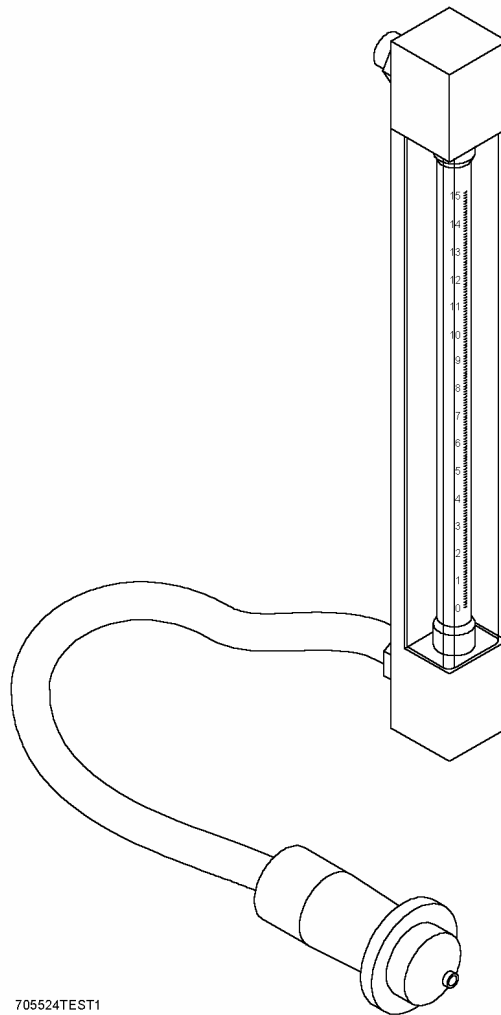

705524TEST1

FIGURE 4
FLOWRATOR Meter for Leakage Test

1.5 MECHANICAL MANOMETER (FIGURE 5)

1.5.1 The mechanical manometer is a diaphragm type device used to determine small pressure differential readings. The manometer dial is purposely graduated to read in pounds per square inch (psi).



FIGURE 5
Manometer

2.0 TEST RACK MAINTENANCE

To secure reliable and uniform results with the "AB" Test Rack, it must be tested as often as required but not less frequently than every 30 days to keep the rack accurate and free from leakage. Each test rack must be tagged or stenciled with the most recent test date. Leakage tests must be made from valve "A", valve "B" and diaphragm cocks and any leakage discovered must be corrected before valves are tested. Air gages must be maintained in a condition to assure accurate registration within ranges of pressure, which they are used and must be sensitive to slight variations of pressure. Strainer and/or filter must be changed or cleaned as conditions require, but not less frequently than once each year.

2.1 Mechanical Manometer

2.1.1 A calibration check on the mechanical manometer must be made as often as necessary to assure proper calibration but not less frequently than once every 6 months. In addition to this, once each year the mechanical manometer must be removed from the "AB" Test Rack, cleaned and calibrated by comparison with a calibration device traceable to the National Standard or accepted Industrial Standard.

2.2 Quick Opening Diaphragm Cock

2.2.1 To adjust the diaphragm tension (or deflection), loosen the cap screw, which serves to clamp the split coupling on the threaded portion of the cover. Screw down or back off the coupling to increase or decrease the diaphragm deflection until the force imparted to the diaphragm by the cam portion of the handle (through the medium of plunger and disc) is just sufficient to prevent leakage past the diaphragm with the handle in closed position.

2.2.2 The clamping cap screw should be tightened when the desired tension on the diaphragm is obtained. The handle position can then be adjusted to the desired angle by loosening three set screws in the handle fulcrum and rotating handle and fulcrum around the clamping coupling. The three set screws must be re-tightened to hold the handle in place and to permit operation of the diaphragm.

2.2.3 Care should be exercised in operating the diaphragm type cocks in order to realize the benefits to be derived from the use of this type cock, that is, eliminating leakage (thereby giving consistent and dependable test results) and obviating the delay and annoyance incident to reseating, lubricating and replacing cock keys.

2.2.4 When the test rack is not in use, all diaphragm cocks should be open. This practice will prolong the life of each diaphragm by preventing permanent set as the diaphragm is in normal position with the cock open.

2.3 Cleaning and Lubrication

2.3.1 The greatest freedom from wear and leakage in the operating parts of the rack will be obtained by keeping them properly lubricated. Rotary valves should be cleaned and lubricated at time of testing the rack on a 30 day basis. If the valves need to be disassembled, cleaned and lubricated more often, leakage test should be made when this is done.

2.3.2 Spool valve type valve "B" requires no maintenance unless leakage is indicated, in which case the spool valve stem and "O" rings must be removed, cleaned and "O" rings replaced if necessary, then lubricated and reassembled into the valve "B" body. The valve must then be tested for leakage according to paragraph 3.2.4.

3.0 TESTING THE RACK

SAFETY PROCEDURES AND WARNINGS:

General shop safety procedures must be followed when performing these specification instructions.

The work area should be clean and free of debris.

WARNING

FAILURE TO OBSERVE THESE PROCEDURES MAY RESULT IN SERIOUS INJURY TO THOSE PERFORMING THE WORK AND/OR THE BYSTANDERS.

DUE TO THE POSSIBILITY OF EXHAUSTING AIR AND HIGH DECIBEL LEVELS OF NOISE ASSOCIATED WITH IT FROM THE DEVICE DURING TESTING; IT IS RECOMMENDED THAT SUFFICIENT HEARING AND EYE PROTECTION BE USED. THIS WILL MINIMIZE THE POSSIBILITIES OF HEARING AND EYE INJURY TO THE OPERATOR OR PERSONS NEAR THE TEST RACK.

BEFORE STARTING THE TEST, MAKE CERTAIN THAT ALL TEST EQUIPMENT AND THE DEVICE TO BE TESTED ARE FASTENED AND/OR CONNECTED SECURELY TO MINIMIZE THE POSSIBILITY OF PERSONAL INJURY FROM PARTS THAT MAY BE "BLOWN" FROM THE TEST ARRANGEMENT WHEN AIR IS ADMITTED TO THE TEST RACK.

AIR WILL VENT FROM SPECIFIC COCK OPENINGS OR PORTS WHEN CERTAIN TEST ARRANGEMENT COCKS ARE OPENED OR VALVES OPERATED. TO MINIMIZE THE POSSIBILITY OF PERSONAL INJURY FROM THE EFFECTS OF VENTING PRESSURIZED AIR, MAKE CERTAIN THAT ALL PERSONS STAND CLEAR OF THE EXHAUST STREAM.

3.1 General Requirements

3.1.1 When preparing to test the rack for leakage, secure the blanking plate, P/N 746417 (TA-2300-C) Pc. 525620, furnished with the rack, to the rack pipe bracket.

3.1.2 In order to avoid the necessity of frequently removing the rack gages for calibration, a new gage fitting connection is provided in the main reservoir line on all modern racks. This connection permits a master test gage (known to be correct) to be applied and a comparison be made between the master gage and the rack gages by manipulation of the proper vent cock. Any rack gage found to be out more than the limit specified in the air gage test should be removed and re-calibrated or repaired when necessary. Since only one master or checking gage is required for each test room, this master gage is not furnished as a fundamental part of the rack, but is available as an accessory to the rack.

3.2 LEAKAGE – TEST NO.1

3.2.1 General Requirements

3.2.1.1 Commence test with all cocks closed except the 1/4" key on the inlet side of the FLOWRATOR Meter, if used, which must remain open at all times, valve "A" handle in position No. 8 and valve "B" in "Cut-Out" position.

3.2.1.2 Drain residual air from the rack by opening cocks 15, 19, 20, 1, 16, 2, 12, 3, 5 and 6. When air has drained, close cocks 15, 19, 20, 1, 16, 2, 12, 3, 5 and 6. Open the supply cock and adjust the test rack feed valve to close at 100 psi.

3.2.2 Valve "A" Rotary Valve

3.2.2.1 Coat the exhaust port of valve "A" with soap suds with valve "A" handle in position Nos. 8, 7, 6, 5 and 4. A 1/2" bubble in not less than 10 seconds is permitted for each respective position.

3.2.2.2 Move valve "A" handle to position No. 1 and charge brake pipe reservoir to 100 psi, then, repeat the soap suds test at valve "A" exhaust port with valve "A" handle in position Nos. 1, 2 and 3. A 1/2" bubble in not less than 10 seconds is permitted for each respective position.

3.2.2.3 Move valve "A" handle to position No. 5 and reduce brake pipe reservoir to 78 psi, then return valve "A" handle to position No. 3. Allow 2 minutes for temperature effect, then observe brake pipe reservoir gage for 1 minute to detect any rise or drop in pressure. No pressure rise or drop is permitted.

3.2.2.4 At completion of test move valve "A" handle to position No. 1.

3.2.3 Diaphragm Cocks-Casting and Diaphragm

3.2.3.1 In the subsequent tests of cocks, leakage found in tests 3.2.3.2, 3.2.3.3, 3.2.3.5 and 3.2.3.12 may also be caused by valve "B" rotary valve and for these four tests, a 1/2" bubble in not less than 10 seconds is permitted at the opening coated with soap suds. No leakage is permitted for the remaining cock tests.

3.2.3.2 Cock 16 (also cock 24, if so equipped) - Open cocks 8 and 19. Coat cock 8 opening with soap suds.

3.2.3.3 Cock 14 - Open cock 2. Repeat the soap suds test at cock 8 opening.

3.2.3.4 Cock 19 - Close cocks 8 and 19 and open cocks 14, 15 and 16 and charge Auxiliary Reservoir to 100 psi. Coat opening of cock 15 with soap suds.

3.2.3.5 Cock 2 - Close cocks 2, 15 and 16 and open cocks 8 and 19. Repeat the soap suds test at cock 8 opening. Close cock 8 and open cocks 2, 16 and 20.

3.2.3.6 Cock 13 - Open cocks 3 and 4. Coat cock 4 opening with soap suds.

3.2.3.7 Cock 17 - Open cock 11. Repeat the soap suds test at cock 4 opening.

3.2.3.8 Cock 11 - Close cock 11 and open cock 17. Repeat the soap suds test at cock 4 opening.

3.2.3.9 Cock 3 - Close cock 3 and open cock 13. Coat the opening of cock 4 with soap suds. Close cock 4 and open cock 3.

3.2.3.10 Cock 9 - Open cocks 5 and 6. Coat cock 6 opening with soap suds.

3.2.3.11 Cock 5 - Close cock 6, then open cock 9 and charge emergency reservoir to 100 psi. Close cock 5 and open cock 6. Coat cock 6 opening with soap suds. Close cock 6 and open cock 5.

3.2.3.12 Cock 20 - Close cocks 2, 16 and 20 and open cock 8. Coat cock 8 opening with soap suds.

3.2.3.13 Cock 1 (also cock 25, if so equipped) - With cock 1 closed, slowly remove the yoke cover and coat the opening in pipe bracket with soap suds. No leakage permitted. Replace the yoke cover.

3.2.3.14 Vent Cocks - Close cock 8 and open cocks 1, 2, 11, 16 and 20. Coat the opening of all vent cocks Nos. 4, 6, 7, 8, 12, 15, 18 and 22 with soap suds.

3.2.4 Valve "B"

3.2.4.1 Commence test with Cocks 1, 2, 3, 5, 9, 11, 13, 14, 16, 17, 19, and 20 open, all other cocks closed, and valve "A" Handle in position No. 1.

3.2.4.2 Close cock 19 and allow Auxiliary Reservoir to equalize at 100 psi for 2-1/2 minutes.

3.2.4.3 Move valve "B" handle to "Cut-In" position. Place valve "A" handle into position 3. Close cocks 16 and 2.

3.2.4.4 Partly open cock 7 to generate approximately 3 psi differential on the manometer. Close cock 7. Wait 90 seconds and then note manometer reading: No change in indication in 30 seconds.

IF FAILURE: SOAP THE BRAKE PIPE LINE, BRAKE PIPE VOLUME AND AUXILIARY LINES AND THEIR ASSOCIATED RESERVOIRS. ALSO CHECK THE MANOMETER LINES AND SEALS ON THE MANOMETER.

3.2.4.5 Coat Valve "B" exhaust port with soap suds with Valve "B" in "Cut-In" and "Cut-Out" positions. No leakage permitted in either position for spool valve type.

3.2.4.6 Open cock 19 and move valve "A" handle to position No. 1.

3.2.5 Reservoirs, Pipe Fittings and Cock Connections

3.2.5.1 With all reservoirs charged to 100 psi, close cocks 9, 13, 14, 16, 17, 19 and supply cock, and move valve "A" handle to position No. 3. Allow one (1) minute for temperature effect, then observe the hands of all gages for one (1) minute to detect any drop in pressure. No pressure drop is permitted.

3.2.5.2 If leakage is indicated, coat all pipe fittings, cock connections and reservoir fittings with soap suds to locate the source of leakage.

3.2.5.3 Close Cocks 1, 2, 3, 5, 11 and 20 and again observe hands of all gages for one (1) minute to detect any drop in pressure. No pressure drop is permitted.

3.3 Air Gages

3.3.1 Commence test with all cocks closed, valve "A" handle in position No. 3 and valve "B" in "Cut-Out" position.

3.3.2 Move valve "A" handle to position no. 8, then, open cocks 12 and 13 and drain brake pipe and main reservoirs. Attach the master test gage to main reservoir gage connection. Close cock 12 and open the supply cock. Move valve "A" handle to position No. 1 and open cocks 1, 2, 3, 5, 9, 11, 14, 16, 17, 19 and 20 and charge entire test rack to 100 psi.

3.3.3 Note that each test rack gage registers within 1/2 psi of the master gage reading. Close the supply cock. Partly open cock 15 and reduce the test rack pressure in steps of 10 psi, and note after each step that the gage hand registers within 1/2 psi of the master gage hand between 100 and 10 psi, and 1 1/2 psi between 10 psi and 0.

3.3.4 Note also if there is any excessive friction in the gage as pressure is being reduced, which will be indicated by gage hand jumping.

3.3.5 At the completion of test, remove the master gage.

3.4 CAPACITY – TEST NO. 2

Commence test with cocks 1, 2, 3, 5, 9, 11, 13, 14, 15, 16, 17, 19 and 20 open, all other cocks closed, valve "A" handle in position No. 1, valve "B" in "Cut-Out" position and test rack drained of all pressure.

3.4.1 Valve "A" Rotary Valve

3.4.1.1 Place valve "A" handle to position No. 3. Close cocks 1, 15 and 16, then open the supply cock.

3.4.1.2 The orifices in valve "A" rotary valve must be checked to insure that they are within the limits specified for each respective position. Be sure that pressures do not change for at least one minute before starting any of the following calibration tests.

3.4.1.3 Position No. 1 - 1/4" Drill Port (.25")

Place valve "A" handle to position No. 1 and charge brake pipe reservoir to 55 psi. Then move valve "A" handle to position No. 3 (Lap). Note that brake pipe reservoir charged at a rapid rate.

3.4.1.4 Position No. 2 - (1/32" Drill Port) (.03125")

Move valve "A" handle to position No. 2 and note brake pipe reservoir pressure must charge from 60 to 70 psi in 6 to 8 seconds, then move valve "A" handle to position No. 3 (LAP).

3.4.1.5 Position No. 3 - Lap

Note that brake pipe reservoir pressure does not increase or decrease from 70 psi.

3.4.1.6 Position No. 4 - (1/32" Drill Port) (.03125")

Place valve "A" handle to position No. 4 and note that brake pipe reservoir pressure must reduce from 70 to 50 psi in 20 to 25 seconds. Move valve "A" handle to position No. 1 and charge brake pipe reservoir pressure to 100 psi, then move valve "A" handle to position No. 3 (Lap).

3.4.1.7 Position No. 5 - (No. 45 Drill Port) (.082")

Move valve "A" handle to position No. 5 and note brake pipe reservoir pressure must reduce from 70 to 40 psi in 3-3/4 to 4-3/4 seconds. Place valve "A" handle to position No. 1 and charge brake pipe reservoir pressure to 100 psi. Then, move valve "A" handle to position No. 3 (Lap).

3.4.1.8 Position No. 6 - (No. 37 Drill Port) (.104")

Move valve "A" handle to position No. 6 and note brake pipe reservoir pressure must reduce from 80 to 10 psi in 9-1/2 to 10-1/2 seconds. Place valve "A" handle to position No. 1 and charge brake pipe reservoir pressure to 100 psi. Then, move valve "A" handle to position No. 3 (Lap).

3.4.1.9 Position No. 7 - (No. 27 Drill Port) (.1440")

Place valve "A" handle to position No. 7 and note brake pipe reservoir pressure must reduce from 80 to 10 psi in 5.2 to 5.6 seconds. Place valve "A" handle to position No. 1 and charge brake pipe reservoir pressure to 100 psi. Then, move valve "A" handle to position No. 3 (Lap).

3.4.1.10 Position No. 8 - (9/32" Drill Port) (.2812")

Move valve "A" handle to position No. 8 and note brake pipe reservoir pressure must reduce from 80 to 10 psi in 1-1/2 to 2-1/4 seconds.

3.4.1.11 At the completion of test, place valve "A" handle to position No. 1.

3.4.2 Auxiliary Reservoir Cocks with Chokes

3.4.2.1 Close cocks 14 and 17. Partly open cock 15 and reduce auxiliary reservoir to 60 psi, then close cocks 15 and 19. Allow one minute for temperature effect.

3.4.2.2 Cock 7 (#63 Drill Choke) (For test rack **without Ring Leakage FLOWRATOR Meter)**

Open cock 7 and note that auxiliary reservoir pressure reduces from 60 to 47 psi in 55 to 62 seconds.

After auxiliary reservoir pressure has reduced to 45 psi, close cock 7 and allow one minute for temperature effect.

3.4.2.2.1 Cock 7 choke plug capacity (For test rack **with Ring Leakage FLOWRATOR Meter)**

Open cock 7 and note that auxiliary reservoir pressure reduces from 60 to 40 psi in 14 to 16 seconds.

Close cock 7. Partly open cock 14 and charge auxiliary reservoir to 45 psi, then close cock 14 and allow one minute for temperature effect.

3.4.2.3 Cock 18 (#73 Drill Choke)

Open cock 18 and note that auxiliary reservoir pressure reduces one psi in 13 to 17 seconds.

Close cock 18.

3.4.2.4 Cock 14 (#50 Drill Choke)

Open cock 14 and note auxiliary reservoir charges from 45 to 55 psi in 9 to 11 seconds.

3.4.3 Cock 22 (#30 Drill Choke) (Used for Service Stability Test)

3.4.3.1 Commence test with cocks 2, 3, 5, 9, 11, 13, 14 and 20 open, all other cocks closed, valve "A" handle in position No. 1 and valve "B" in "Cut-Out" position.

3.4.3.2 Close cocks 3, 5, 9, 11, 13 and 14, then open cocks 1, 16 and 19 and charge brake pipe, auxiliary and quick action chamber reservoirs to 100 psi. Place valve "A" handle to position No. 4 and reduce brake pipe reservoir to 80 psi. Then move valve "A" handle to position No. 3.

3.4.3.3 Allow two minutes for temperature effect. If necessary, adjust brake pipe reservoir to 80 psi with valve "A" handle. Quickly open cock 22 and note that the pressure indicated at brake pipe volume gage reduces from 80 to 30 psi in 31 to 32 seconds. Close cock 22.

NOTE

This test is based on a predetermined rate of brake pipe reduction, which should be obtained if the recommended standard choke is used. If however, due to tolerance variation in reservoir volumes, deviation from the above blow-down time is encountered, it can and must be corrected by carefully increasing or decreasing the choke capacity as the case may be. In all cases the orifice face of the choke plug should be lapped smooth to produce a sharp leading edge.

3.5 MECHANICAL MANOMETER – TEST NO. 3

3.5.1 Apply the AB-160 test plate, P/N 747039 (TA-2941-C) Pc. 564225, to the face of the rack pipe bracket.

3.5.2 Open cocks 3, 16 and 13 and move valve "A" handle to position No. 1. Move Valve "B" to "Cut-In" position and close cock 16. After one minute, note that the hand of the manometer indicates between positions No. 4 and 5 on its dial. If it does not, the manometer must be removed for re-calibration by comparison with a suitable liquid manometer.

3.5.3 At the completion of this test, open cock 16 and move valve "B" to "Cut-Out" position. Then close cock 13, open cock 4, and move valve "A" handle to position No. 8. Then close all cocks and remove the test plate.

3.6 Valve "B" Positions

3.6.1 "Cut-In" Position (To right for rotary valve type and Pull out for spool valve type):
Connects top of liquid manometer to auxiliary reservoir and bottom to brake pipe, or bottom of mechanical manometer to auxiliary reservoir and top to brake pipe.

3.6.2 "Cut-Out" Position (To left for rotary valve type and Pushed In for spool valve type):
Connects both top and bottom of manometer to atmosphere.

ENGINEERING DEPARTMENT

REVISION PAGE:

NYT-909-C

ISSUE NO. 1
MAY 28, 1982

Original Issue.

ISSUE NO. 2
OCTOBER 18, 2000

Re-wrote entire code with information from obsolete
S-4016.

ISSUE NO. 3
MAY 21, 2001

Para. 3.4.2.2.1 – 40 psi was 47 psi.

ISSUE NO. 4
NOVEMBER 1, 2007

Para. 3.4.1.4 – 6 to 8 seconds was 10 to 12 seconds.
Added P/N's 702546 & 702612 to the Title Page.

ISSUE NO. 5
FEBRUARY 12, 2009

Pg. 1 - Added current P/N's to list of accessories.
Pg. 1 - Added accessory 9 to list - used in 3.5 - Test No. 3.
Pg. 1 - "Diagrammatic view and arrangement..." statement
added.
Pg. 4 - 1.2 - Cock 22 - Added current P/N's.
Pg. 9 - 3.1.1 - Added current P/N.
Pg. 15 - 3.5.1 - Added current P/N.
Updated NYT-909 to Rev C.

